

## Heathfield 5W led COB MR16 lamp range

### Features In Brief:

1. Replaces 50w halogen MR16
2. Low heat, no UV or IR
3. Aluminium alloy shell
4. Effective heat dissipation system
5. 90° beam angle
6. >50,000hrs (see website for details)



Heathfield LED MR16 lamps are designed to replace the traditional halogen variety offering an energy saving alternative. The lamps are compatible with most electronic transformers within the market place. Depending on the lamp style you prefer we offer 2 varieties, one style is "Chip on board" technology and the other being "SMD". Our COB lamps offer a wide beam angle of 90 degrees whilst the SMD version offers 60 degrees. Utilizing branded LED chips these products are manufactured to commercial standards to ensure true lifetime claims.

Part Number	Colour	Luminous Flux
H5MR16/6000K/COB	6000K	330 lm
H5MR16/4000K/COB	4000K	320 lm
H5MR16/3000K/COB	3000K	300 lm

## Heathfield 5W led COB MR16 lamp Features

### 5w Range

Item	H5MR16/6000K/COB	H5MR16/4000KCOB	H5MR16/3000K/COB
Input voltage	AC 100-240V	AC 100-240V	AC 100-240V
Power consumption	5W	5W	5W
Colour	6000K	4000K	3000K
Colour temperature	Daylight	Cool white	Warm white
Life time	>50,000 hrs	>50,000 hrs	>50,000 hrs
Operating temperature	-10°C to + 40°C	-10°C to + 40°C	-10°C to + 40°C
Dimensions	50.8xø5mm	50.8xø5mm	50.8xø5mm
Lumen	330lm	320lm	300lm
Certificates	CE, RoHS	CE, RoHS	CE, RoHS
Beam angle	90°	90°	90°
Weight	45g	45g	45g
CRI	80	80	80

### Dimensions

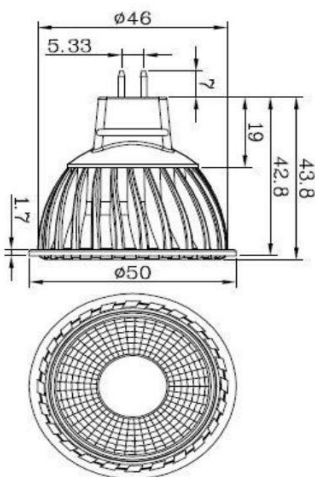

### Spectrophotometer test report

